

**BIESEMEYER® T-SQUARE®
Commercial Fence System**

(Model BC30)
(Model BC30W)
(Model BC50)
(Model BC50W)

INSTRUCTION MANUAL

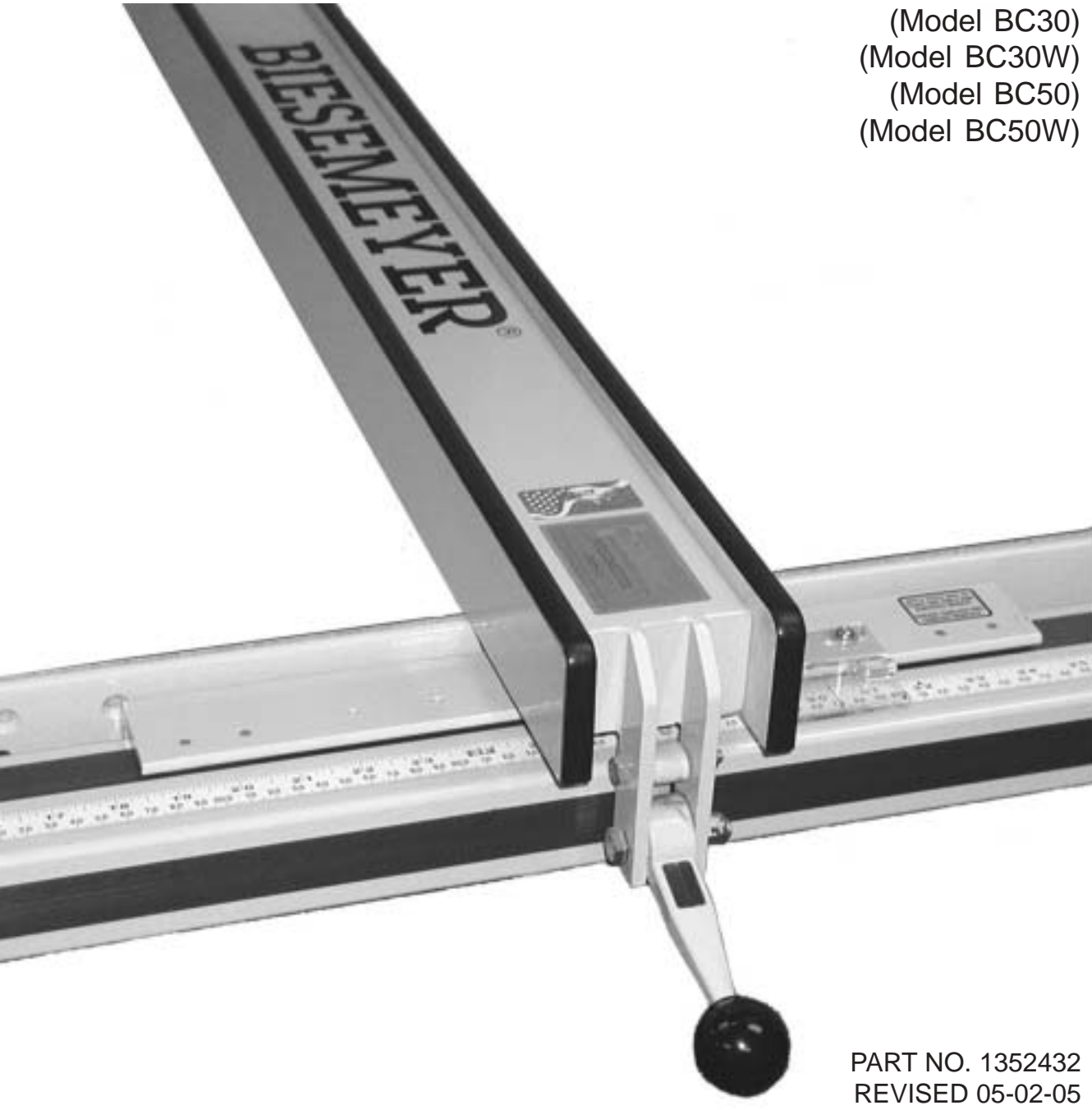

PART NO. 1352432
REVISED 05-02-05

BIESEMEYER®

To learn more about BIESEMEYER MANUFACTURING
visit our web site at: www.biesemeyer.com.
For Parts, Service, Warranty or other assistance,
please call **1-800-782-1831**

INTRODUCTION

The BIESEMEYER® T-SQUARE® Commercial fence system includes the fence assembly, front rail, rear rail and front guide tube along with the mounting hardware for assembling the fence system to many different types of table saws. Depending on the model ordered, an accessory leg kit may also be included. An accessory right extension table and support legs are also required. The right extension table may be purchased separately or may be constructed by following the diagram in this manual. If the leg kit is not included with the fence, it may be ordered separately as well. **IMPORTANT:** The BIESEMEYER® T-SQUARE® Commercial fence system is designed to be used only with a supporting extension table and leg kit.

UNPACKING

Carefully unpack the BIESEMEYER® T-SQUARE® Commercial fence system from the shipping cartons. Fig. 1 illustrates all the items supplied with the guide set. Fig. 2 illustrates all the items supplied in the fence box. Support legs shown are only provided with Part No. 78-200. Fig. 3 illustrates the accessory right extension table. NOTE: If you did not purchase the right extension table for use with your T-SQUARE® fence system, refer to the next section titled "Constructing Extension Table" for information on constructing an extension table.

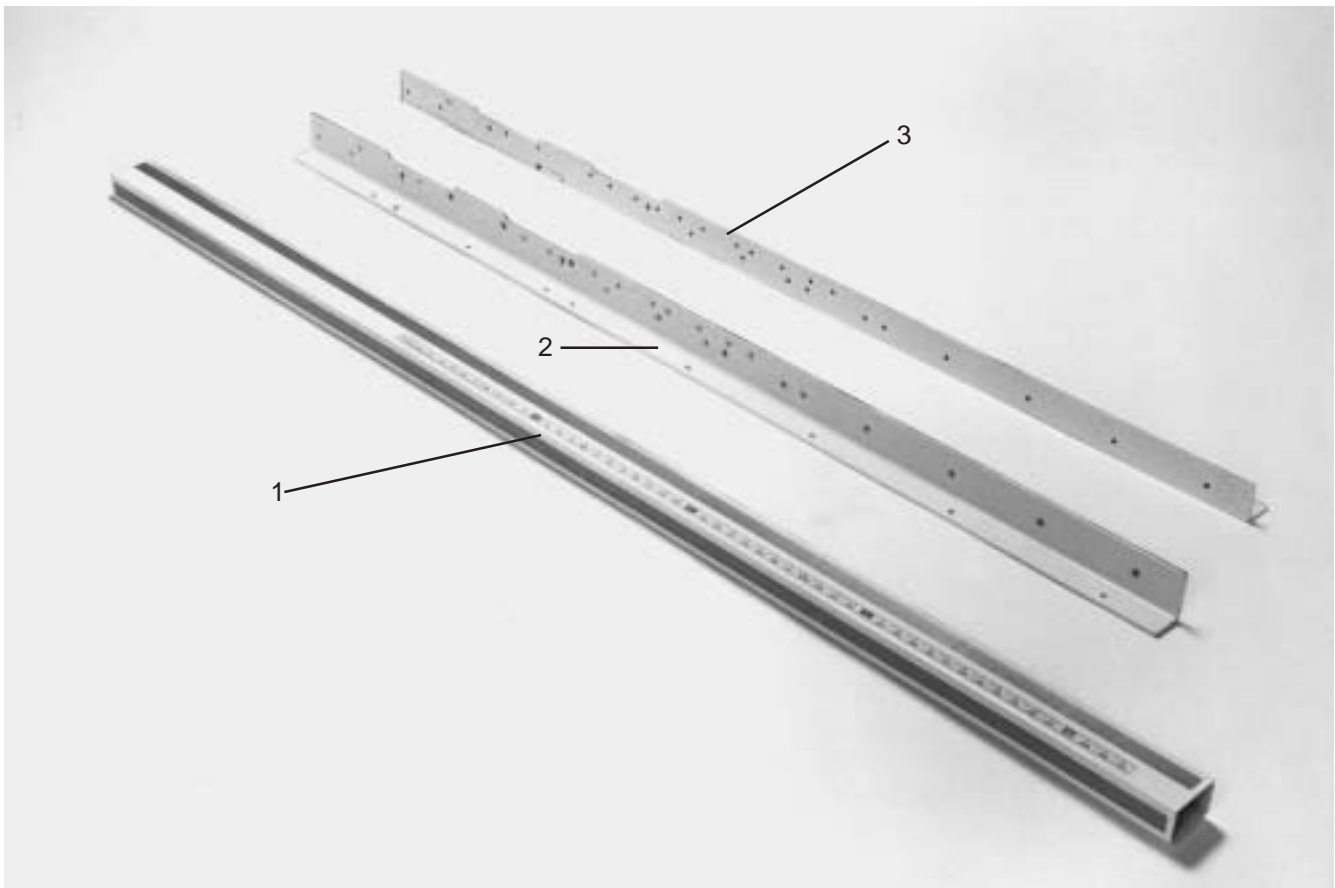

Fig. 1

1. Guide Tube
2. Front Rail
3. Rear Rail

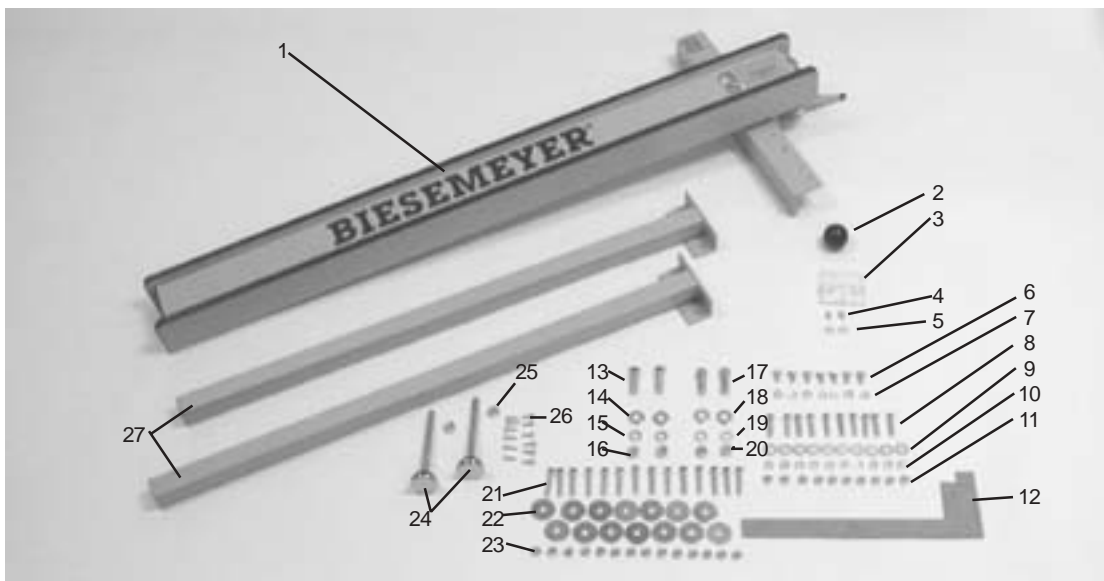

Fig. 2

- 1. T-Square® Fence
- 2. Knob
- 3. Hairline Pointer
- 4. #10-32 x 3/8" Round HD Screw (2)
- 5. Flat Washer (2)

For Attaching Guide Tube to Front Rail

- 6. 1/4-20 x 1/2" Hex HD Screw (7)
- 7. 1/4" Lock Washer (7)

For Attaching Front and Rear Rail to Non-Delta Saws

- 8. 1/4-20 x 1-1/4" Flat HD Screws (10)
- 9. 1/4" Flat Washer (10)
- 10. 1/4" Lock Washer (10)
- 11. 1/4-20 Hex Nut (10)

- 12. Template

For Attaching Front Rail to Delta Unisaw/Contractor Saw

- 13. 5/16-18 x 1-1/2" Flat HD Screw (2)
- 14. 5/16 Flat Washer (2)
- 15. 5/16 Internal Tooth Lock Washer (2)
- 16. 5/16-18 Hex Nut (2)

For Attaching Rear Rail to Delta Unisaw/Contractors Saw

- 17. 3/8-24 x 1-1/4" Hex HD Screw (2)
- 18. 3/8" Flat Washer (2)
- 19. 3/8" Lock Washer (2)
- 20. 3/8" Hex Nut (2)

For Attaching Extension Table (All Saws)

- 21. 1/4-20 x 1-1/2" Flat HD Screw (14)
- 22. Fender Washer (14)
- 23. 1/4-20 Hex Nut (14)

24-27 Provided with 78-200 ONLY

- 24. Leveling Foot (2)
- 25. 3/8-16 Hex Nut (2)
- 26. #10-28 x 5/8" Pan HD Screw (12)
- 27. Support Leg (2)

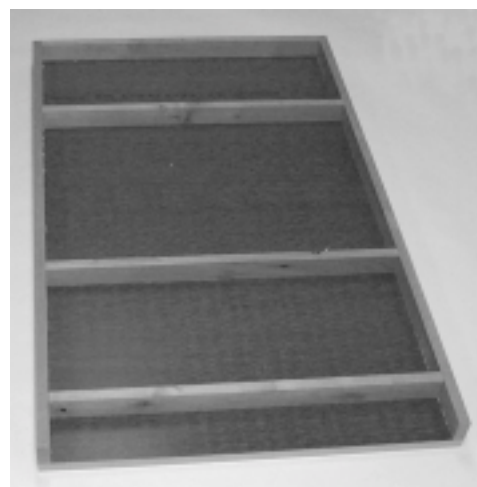

Fig. 3

CONSTRUCTING EXTENSION TABLE

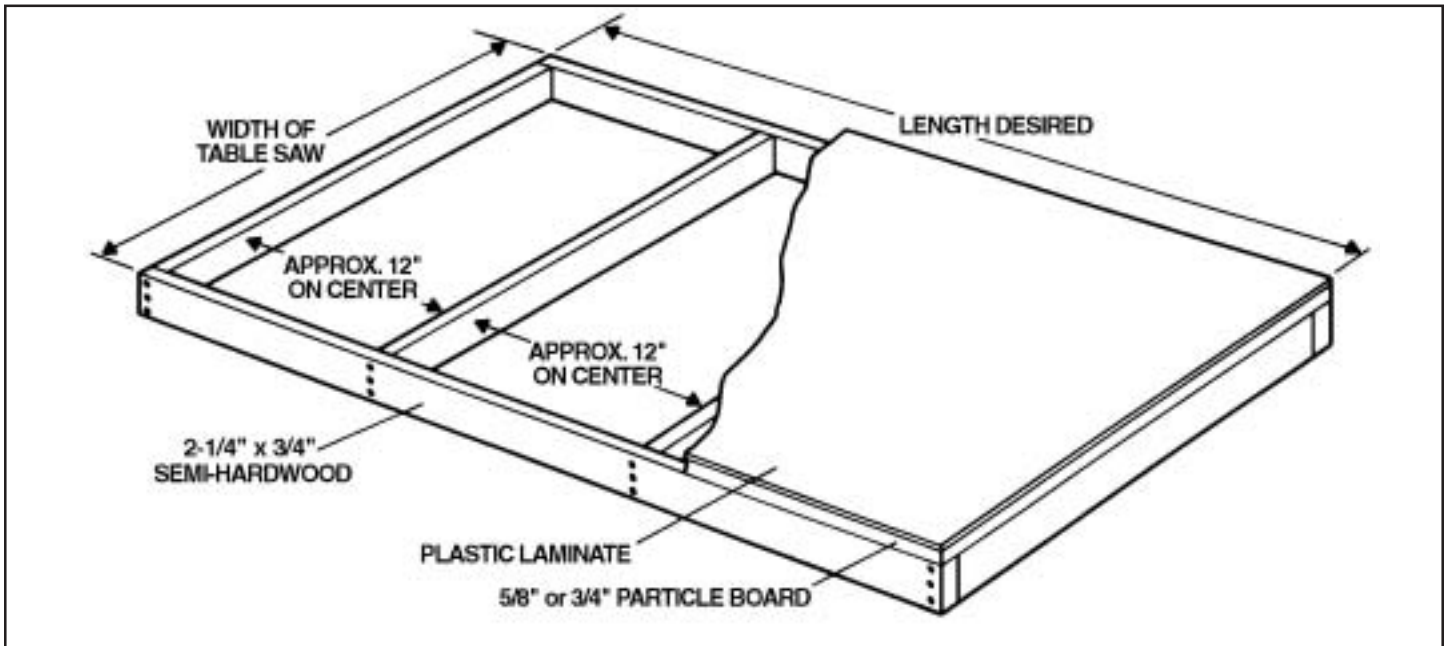

Fig. 4

ASSEMBLY (DELTA UNISAW OR DELTA CONTRACTOR'S SAWS ONLY)

FOR ALL OTHER SAWS, PROCEED DIRECTLY TO PAGE 7, STEP 1.

DISCONNECT THE SAW FROM THE POWER SOURCE!

FRONT RAIL TO SAW

1. Assemble front rail (A) Fig. 5 to the front edge of the saw table using the two 5/16-18 x 1-1/2" long flat head Phillips screw, flat washer, internal tooth lock washer and 5/16" hex nut (B) supplied. Screws are inserted through the two larger countersunk holes in the front rail and into the two holes in the front of the saw table and fastened with the flat washer, internal tooth lock washer and hex nut. **IMPORTANT:** Do not tighten front rail mounting hardware at this time.

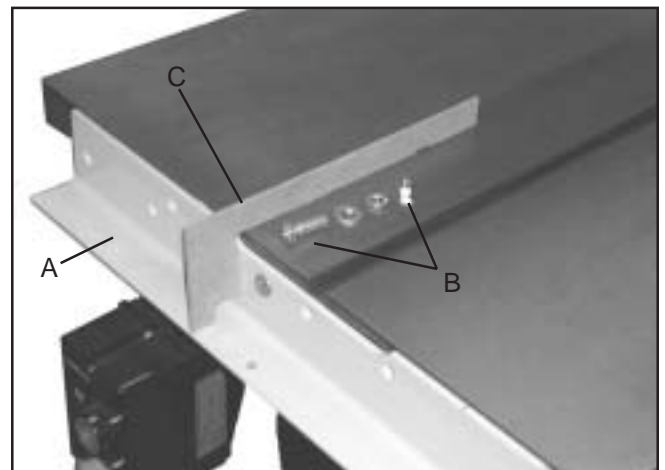

Fig. 5

FOR DELTA CONTRACTORS SAWS ONLY

Attach the on/off switch to the front rail mounting bolt as shown in Fig. 6.

2. Using template (C) Figs. 5 & 7, Check and adjust the front rail on both sides of the saw blade as shown, to make sure the rail is parallel with the table surface. The horizontal portion of the rail should be down from the top of the table surface 2-27/32". Tighten the front rail mounting hardware when you are certain the rail is set at the proper depth.



Fig. 6

REAR RAIL FOR DELTA SAWS

NOTE: Do not use template to set rear rail.

3. Align the two non-countersunk holes in the rear rail with the two holes in the rear edge of the saw table. The two cutouts in the rail should be approximately 1/16" below the bottom of the two miter slots in the saw. Fasten rear rail to the saw as follows:

For Delta Unisaw Thread the two 3/8-24 x 1-1/4" long hex head screw, lock washer and flat washer (D), supplied, Fig. 8, through the two holes in the rail and into the two threaded holes in the saw table.

For Delta Contractor's Saws Fasten rail to the saw using the two 3/8-24 x 1-1/4" hex head screws, lock washers, flat washers and hex nuts (E) supplied Fig. 9. The lock washer, flat washer and hex nut will be on the inside edge of the saw table.

4. After fastening the rear rail to the saw table, tilt the saw blade to make certain there is no interference between the guard splitter and the rear rail. If there is, it will be necessary to enlarge the cut-out (F) in the rear rail.

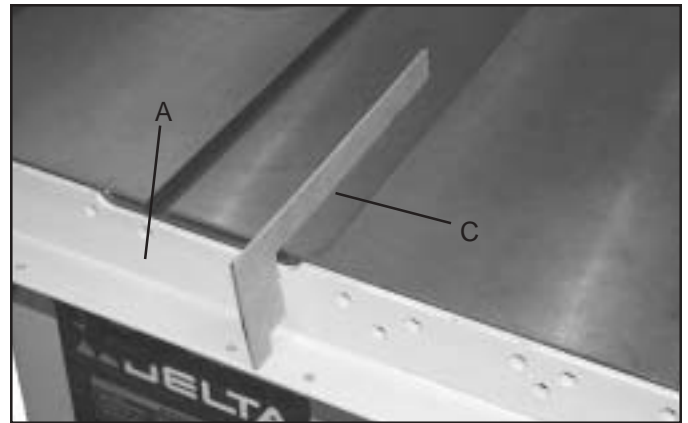

Fig. 7

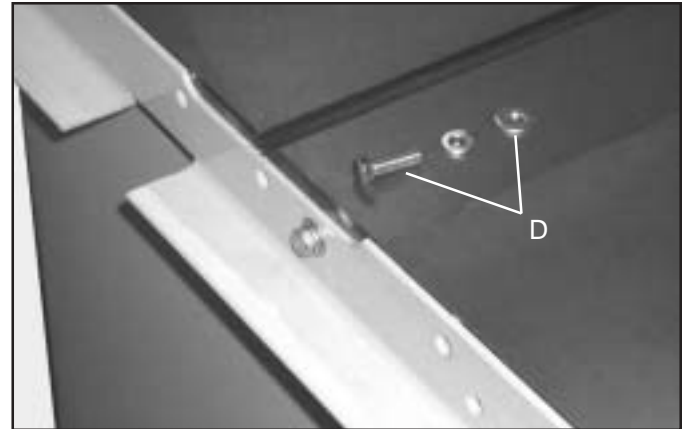

Fig. 8

TABLE LEGS TO TABLE BOARD

5. Assemble the 3/8" jam nut (G) onto leveling screw (H). Thread leveling screw into bottom of support leg. Fig. 10 illustrates the foot leveling assembly on the table leg. Assemble the remaining foot assembly to the other leg in the same manner. **NOTE:** Height adjustment will be made later.

6. Lay the table upside down on the floor or on a bench.

7. Position the table leg (I) to the closed in corner of the extension table (J) as shown in Fig. 11.

8. Attach the table leg to the table board with six 5/8" long wood screws (K). Repeat this process for the remaining leg.

IMPORTANT: If your saw fence system will be used with a mobile base underneath the saw base and table legs, the position of the legs will have to be changed to fit the mobile base extension.

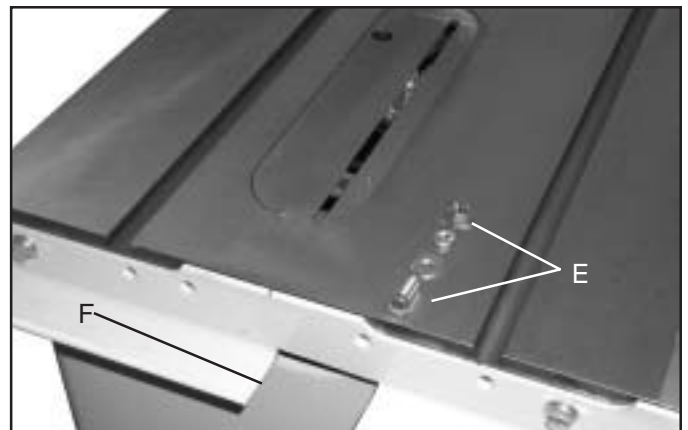

Fig. 9

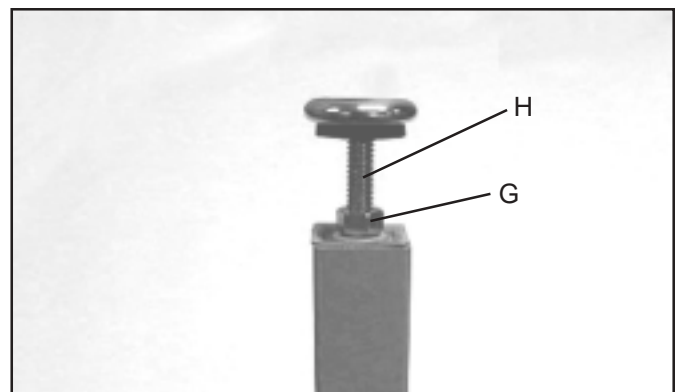

Fig. 10

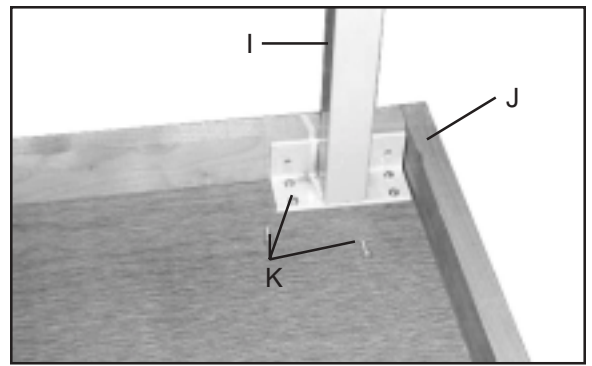

Fig. 11

NOTE: Table shown installed on a Unisaw without the cast iron wing. If your saw has a cast iron extension wing on the right hand side, it is not necessary to remove the wing. The extension table can extend past the rails and tube.

9. Place table assembly (L) Fig. 12, in position between the two rails, as shown. Make sure end of table is flush against saw table (M). Using a straight edge make sure table (L) is in the same plane and level with saw table (M). Lightly tap up or down and adjust leg leveling screws. When you are certain table (L) is level and in the same plane with saw table (M) tighten bar clamp (P) to hold everything in position. Then drill 1/4" holes through the front and rear of the extension table using holes (Q) provided in rails as a template. **NOTE:** Number of holes (Q) in the front and rear rails will vary depending on the length of the rails you purchased.

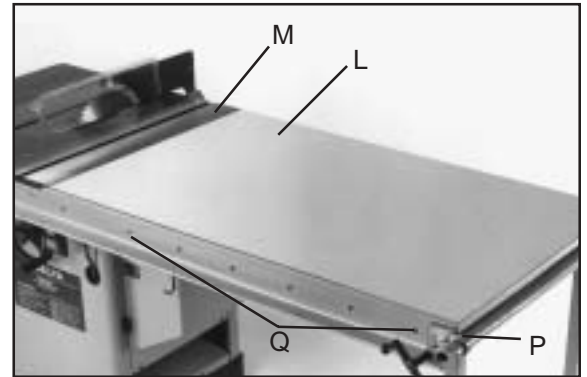

Fig. 12

10. After the holes have been drilled in the edge of the front and rear extension table board, fasten both front and rear rail to table using the 1/4-20 x 1-1/2" flat head Phillips screws, 1-1/4" O.D. flat washers and hex nuts (R).

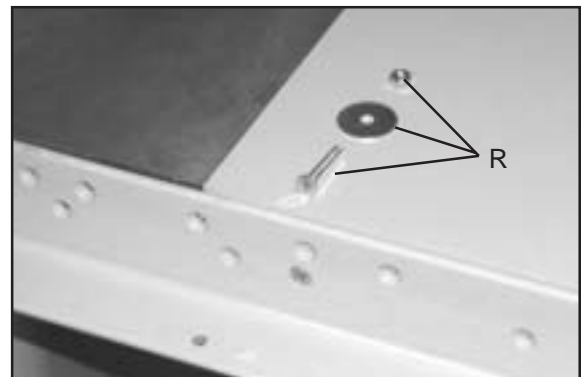

Fig. 13

11. Lay the guide tube (B) Fig. 14, on the saw table as shown, and line up the threaded holes (S) on the bottom of guide tube with the through holes (T) on the front rail. **NOTE: The guide tube should extend past the rail 6" on each end.**

12. Position the guide tube (B) on the front rail and fasten the guide tube to the rail using the 1/4-20 x 1/2" long hex head screws and lock washers. **NOTE:** Where there are two holes 2-1/2" apart, use only the left hole.

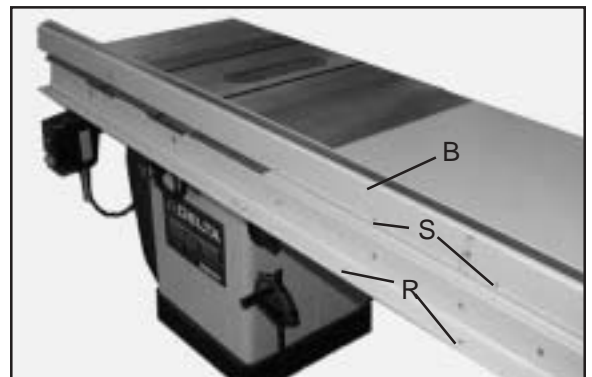

Fig. 14

PROCEED TO STEP ONE ON PAGE 9

ASSEMBLY (FOR ALL OTHER SAWS)

DISCONNECT THE SAW FROM THE POWER SOURCE!

ASSEMBLE FRONT RAIL

1. Raise saw blade (A) Fig. 15. Place a straight edge (B) against the right side of saw blade extending out over the front of the saw as shown. Position front rail (C) against the edge of saw table and lightly clamp in place using bar clamps (D). Align notch (E) in front rail (C) with the straight edge (B) as shown. **NOTE: Any portion of the notch needs to align with the straight edge. Final calibration will be explained later.**

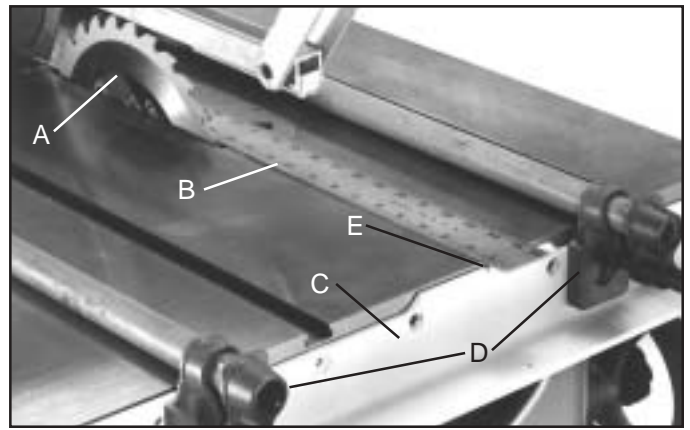

Fig. 15

2. Using template (F) Fig. 16, check and adjust the front rail at both sides of saw table, to make sure the horizontal portion of front rail (C) is parallel with the table top and then tighten bar clamps. The rail should be down from the top of the table 2-27/32".

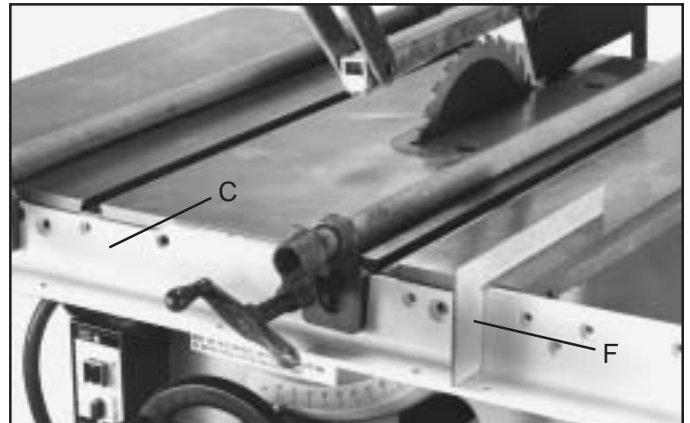

Fig. 16

3. When you are certain front rail (C) is level with the table surface, drill four 1/4" through holes into the saw table using the 1/4" counter sunk holes in the front rail as a template. **IMPORTANT: Before drilling, check to make certain there is no interference such as casting ribs behind front edge of saw table.**

4. Fasten front rail (C) to saw table using the four 1/4-20 x 1-1/4" long flat head screws, flat washers, lock washers and hex nuts supplied.

ASSEMBLE REAR RAIL

5. Clamp rear rail (G) Fig. 17, to back of saw table using bar clamps making certain notch (E) in rail is aligned with saw blade (A) as shown, using straight edge (B). Make sure the two cutouts in the rail are 1/16" below the bottom of the miter slots in the saw table.

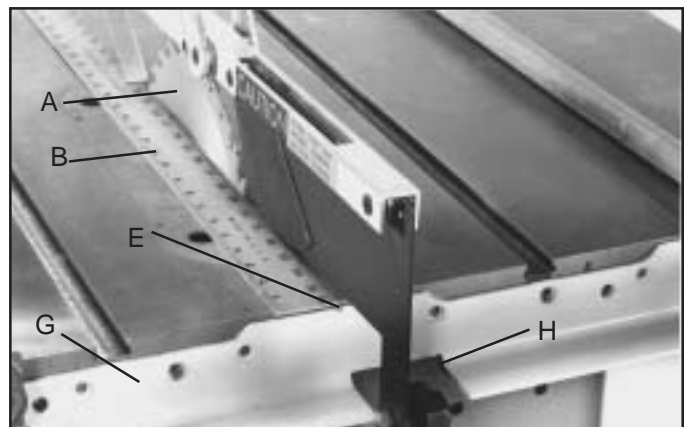

Fig. 17

6. Check to make certain there are no interference such as casting ribs behind the rear edge of the saw table and drill a minimum of two through holes into the saw table using the countersunk holes as a template. Fasten rear rail to saw table using the 1/4-20 x 1-1/4" long flat head screws, flat washers, lock washers and hex nuts supplied. **IMPORTANT: if there is no room in rear edge of the table to drill through holes, it will be necessary to drill #7 holes and tap holes with a 1/4-20 tap.**

7. After fastening the rear rail to the saw table, tilt the saw blade to make certain there is no interference between the saw guard and the rear rail. If there is, it will be necessary to enlarge the cut-out (H) Fig. 17, in the rear rail.

EXTENSION TABLE & SUPPORT LEGS

8. Assemble the 3/8" jam nut (I) onto leveling screw (J). Thread leveling screw into foot adapter. Fig. 18 illustrates the foot leveling assembly on the table leg. assemble the remaining foot assembly to the other leg in the same manner. **NOTE: Height adjustments will be made later.**

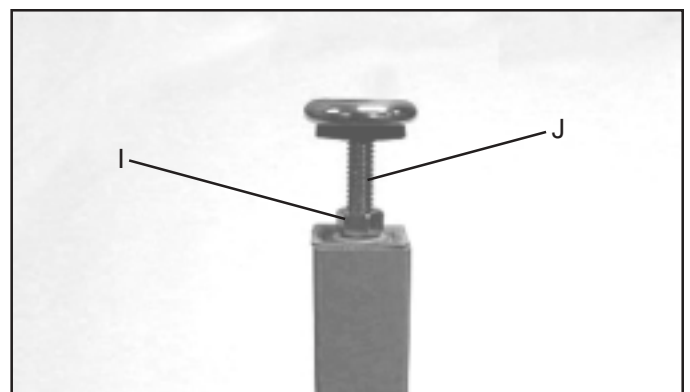

Fig. 18

9. Lay the extension table upside down on a floor or bench.

10. Position leg (K) to bottom to location in table board (L) as shown in Fig. 19.

11. Attach the table leg (K) to the table board (L) with six 5/8" long wood screws (M). Repeat this process for the remaining leg.

IMPORTANT: If your saw fence system will be used with a mobile base underneath the saw base and table legs, the position of the legs will have to be changed to fit the mobile base extension.

12. Place table assembly (L) in position between the front and rear rail, as shown in Fig. 20. Make sure end of table is flush against saw table and using a bar clamp, snug up ends of rails to hold table in position. Using a straight edge, (N), make certain table is in the same plane and level with saw table. Adjust leveling screws in bottom of support legs to accomplish this. When you are certain table is level and in the same plane as the saw table, tighten bar clamp to hold everything in position. Then drill 1/4" through holes through the front and rear table frame using holes (O) in the rail as a template. The number of holes to drill will depend on the length of the rails.

13. After the holes have been drilled in the front and rear table frame, fasten both front and rear rail to table Fig. 21 using the 1/4-20 x 1-1/2" long flat head screws, fender washers and hex nuts (P) provided.

14. Lay guide tube (Q) Fig. 22, on saw table as shown, and line up the threaded holes (R) in bottom of guide tube with through holes (S) in the front rail. Guide tube will extend 6" past the rail at both ends.

15. Lay guide tube on front rail and fasten the guide tube to the front rail using the 1/4-20 x 1/2" long hex screws and lockwashers provided. NOTE: Where there are two holes 2-1/2" apart, use only the left hole.

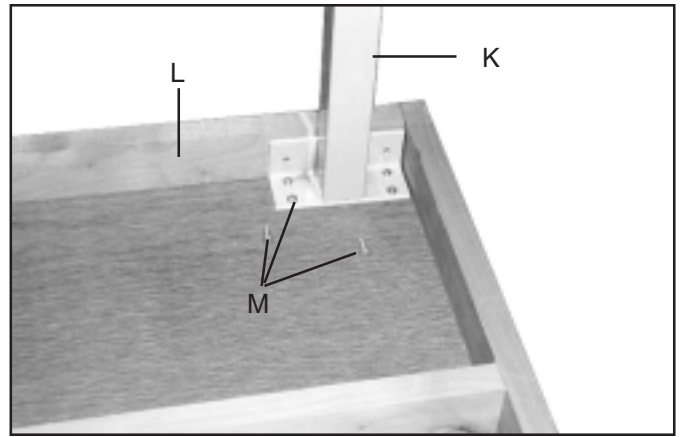

Fig. 19

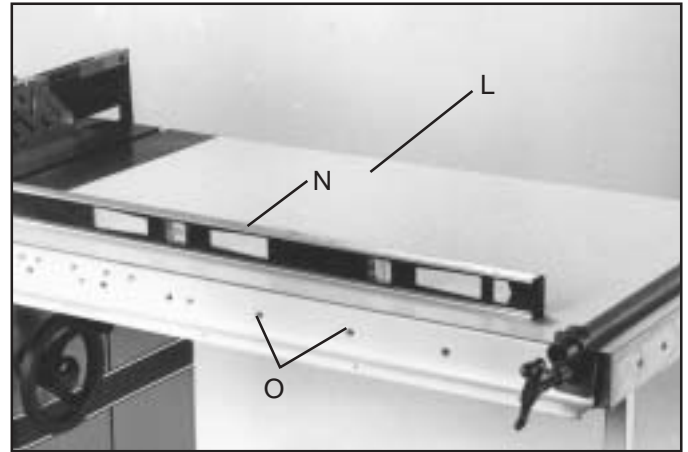

Fig. 20

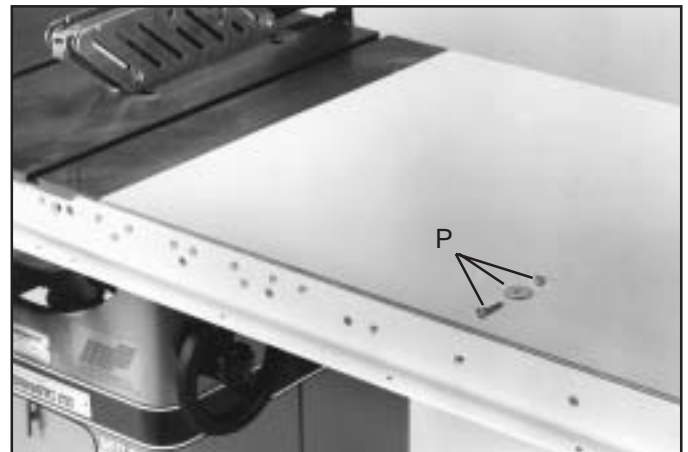

Fig. 21

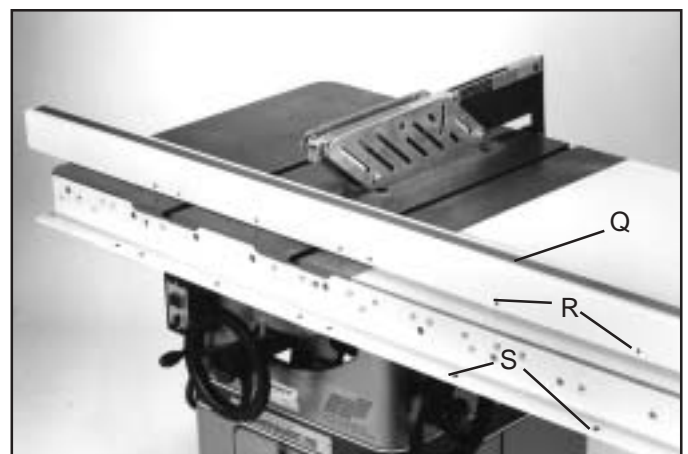

Fig. 22

ASSEMBLY (FOR ALL SAWS)

1. Attach knob (A) Fig. 23 to locking knob (B). Knob is screwed onto threads of locking handle.

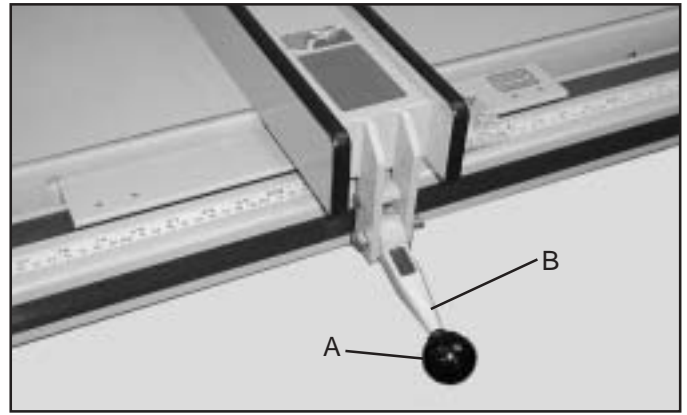

Fig. 23

2. Align fence side (C) Fig. 24, with the miter slot on the table saw and lock fence in position. Using a measuring tape (D), measure the distance from the saw blade to the fence side.

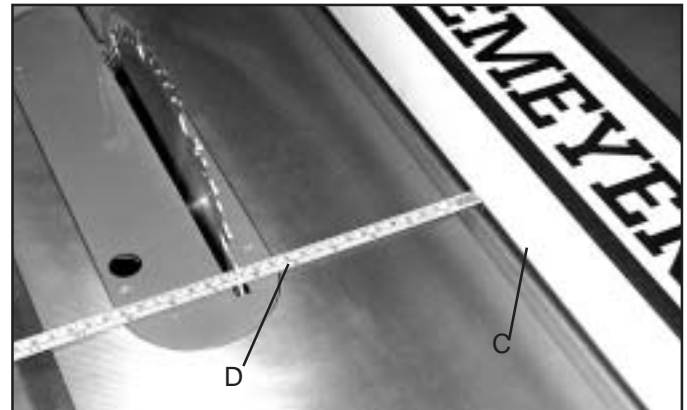

Fig. 24

3. WITHOUT MOVING THE FENCE, attach hairline pointer (E), Fig. 25 to fence crossarm (F) using two #10-32 x 3/8" round head screws and flat washers (G). Screws go through the slotted holes in the pointer and into the threaded holes (H) in the crossarm. Using the measurement from Step 2, align the black line in the pointer to the same measurement on the guide tube tape and securely tighten screws.

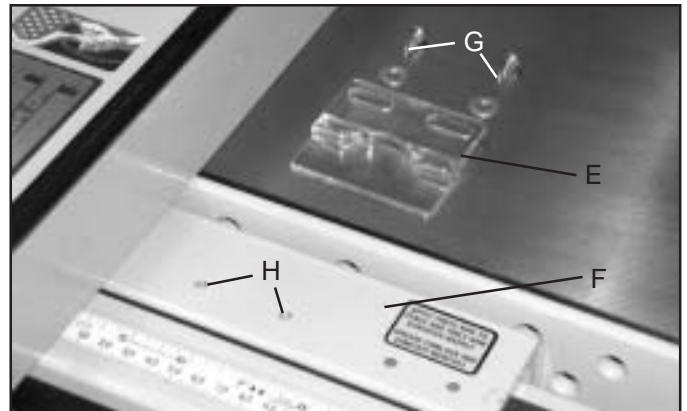

Fig. 25

IMPORTANT: CHECK TO MAKE CERTAIN THAT THE MITER GAGE SLOTS IN THE SAW TABLE ARE PARALLEL WITH THE SAW BLADE. CHECK WITH THE INSTALLATION MANUAL THAT CAME WITH YOUR SAW FOR INSTRUCTIONS.

4. The fence (C) Fig. 26, must be adjusted so it is parallel to the miter gage slot. Slide the fence until the bottom edge is in line with the edge of the miter gage slot as shown and push down on locking handle (B). Check to see if the fence (C) is aligned with the miter slot the entire length of the table. If an adjustment is needed, lift fence (C) off the guide as shown in Fig. 27. Slightly tighten or loosen adjusting screws (J) or (K), using a 3/16" Allen wrench (N), not included. Replace the fence on the guide tube and check again. Repeat this adjustment until you are certain the fence is parallel to the miter gage slot. **NOTE: Very little movement of the adjusting screws is necessary to adjust the fence.**



Fig. 26

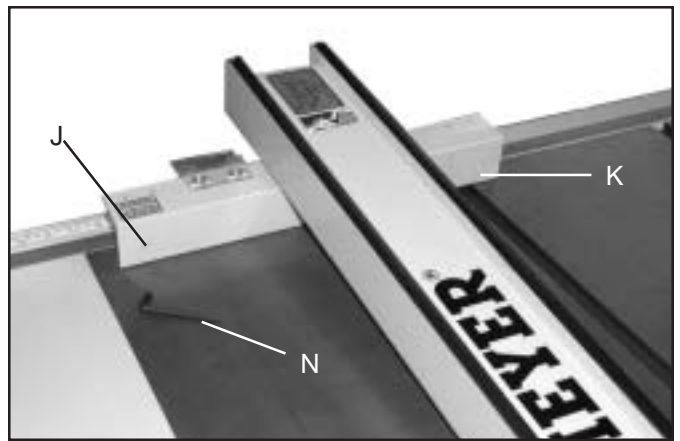

Fig. 27

5. When the fence locking handle (B) Fig. 28, is pushed to the down position, the fence assembly (C) should be completely clamped to the guide tube. If the fence assembly (C) is not completely clamped to the guide tube when the handle is pushed down, as shown, lift up handle (B) and raise fence off the guide tube as shown in Fig. 27. Slightly tighten the two adjusting (J) and (K) (if the fence is too loose) or loosen (if the fence is too tight), using a 3/16" Allen wrench (N), not supplied. **NOTE: Screws (J) and (K) should be tightened or loosened an equal amount.** Replace the fence back on the guide tube and recheck to see if the fence assembly is completely tightened to the guide tube with the locking handle (B) pushed down. Adjust further if necessary.

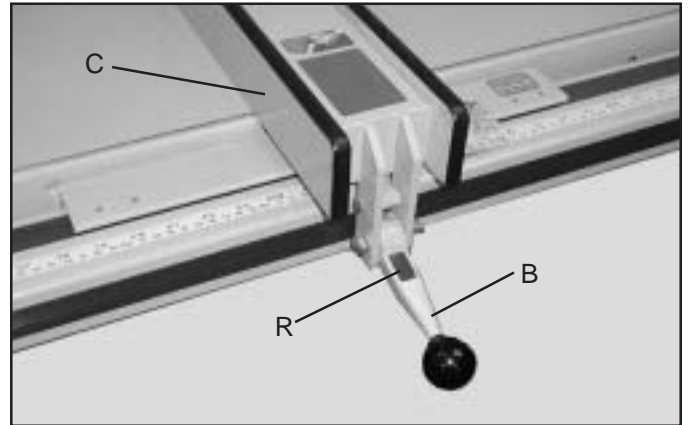

Fig. 28

IMPORTANT: AFTER ADJUSTING THE FENCE CLAMPING ACTION, RECHECK TO SEE THAT THE FENCE IS STILL PARALLEL TO THE MITER GAGE SLOT AND ADJUST AS NECESSARY.

6. When clamping the fence assembly (C) to the guide tube, make certain the camfoot (P), Fig. 29, is hanging down and against the locking handle (B), and not caught on top of the guide tube.

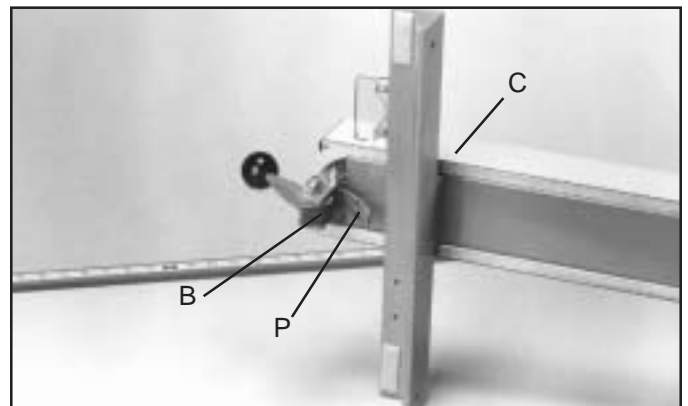

Fig. 29

7. To move the fence along the guide tube, simply lift up the locking handle (B) Fig. 30, as shown, slide the fence to the desired position on the guide, and push down locking handle (B) Fig. 28 as shown, to lock in position. **NOTE:** A magnet (R) Fig. 28, is provided to hold the handle in the up position when moving the fence.

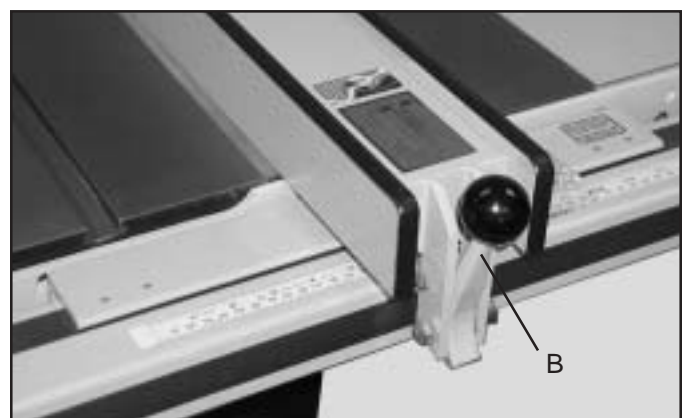

Fig. 30

9. The distance the fence is positioned away from the saw blade is indicated by the witness line (S) located in cursor (E), Fig. 31. To calibrate the cursor to the saw blade, make a test cut with the fence locked in position. Measure the width of the cut piece. Adjust the cursor by loosening screws (G), adjusting the cursor until the witness line is aligned with the same marking on the scale as the cut piece. Tighten the two screws (G). Repeat until the width of the cut piece matches the measurement indicated by the witness line.

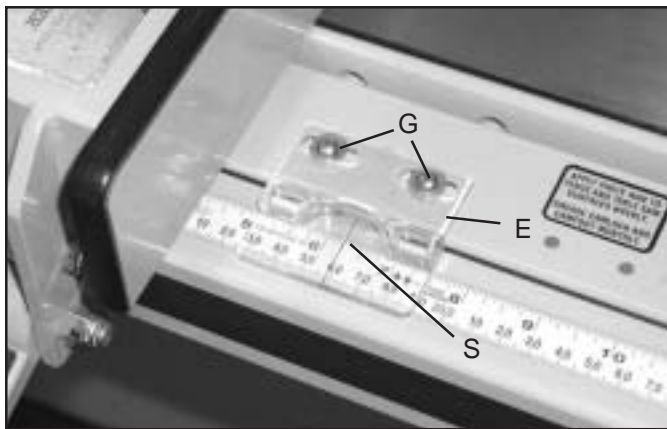

Fig. 31

10. Apply grease to locking handle (B) and camfoot (P) Fig. 32, monthly to prevent wear.

11. Apply paste wax to the fence sides and the unpainted guide tube sliding surfaces weekly. Meguiar's Professional Past Wax (M-1611) is recommended. Also, saw table and extension table surface should be waxed.

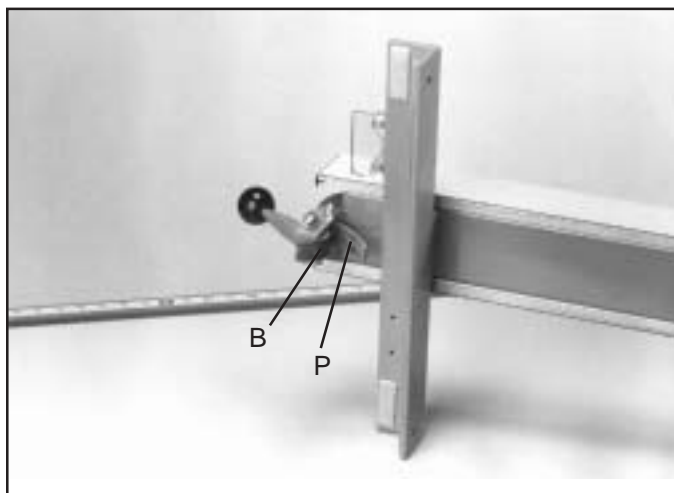

Fig. 32



TWO YEAR LIMITED NEW PRODUCT WARRANTY

Delta will repair or replace, at its expense and at its option, any new Delta machine, machine part, or machine accessory which in normal use has proven to be defective in workmanship or material, provided that the customer returns the product prepaid to a Delta factory service center or authorized service station with proof of purchase of the product within two years and provides Delta with reasonable opportunity to verify the alleged defect by inspection. For all refurbished Delta product, the warranty period is 180 days, Delta may require that electric motors be returned prepaid to a motor manufacturer's authorized station for inspection and repair or replacement. Delta will not be responsible for any asserted defect which has resulted from normal wear, misuse, abuse or repair or alteration made or specifically authorized by anyone other than an authorized Delta service facility or representative. Under no circumstances will Delta be liable for incidental or consequential damages resulting from defective products. This warranty is Delta's sole warranty and sets forth the customer's exclusive remedy, with respect to defective products; all other warranties, expressed or implied, whether of merchantability, fitness for purpose, or otherwise, are expressly disclaimed by Delta.